

Highly Damping Hard Coatings for Protection of Titanium Blades

Prof. Boris A. Movchan and Prof. Anatolii I. Ustinov

International Center for Electron Beam Technologies of
E.O. Paton Electric Welding Institute of
National Academy of Science of Ukraine
68 Gorky str, Kyiv 03150
UKRAINE

movchan@paton-icebt.kiev.ua;ustinov@paton-icebt.kiev.ua

ABSTRACT

Sn-Cr-MgO system is used as an example to show the basic capability to produce by EBPVD protective metal-ceramic coatings with a high adhesion strength, high values of hardness and damping capacity on the surface of titanium alloys at substrate temperatures not higher than 400°C. After deposition of such coatings on the surface of titanium samples their endurance limit is preserved. It allows these coatings to be regarded as promising in terms of extending the service life of titanium blades. The paper deals with the features of coating structure ensuring their unusual combination of mechanical properties, and presents model concepts of the possible mechanisms of vibration energy dissipation in them.

1.0 INTRODUCTION

Titanium alloys, for instance Ti-6%Al-4%V alloy, have become widely applied as materials for manufacture of compressor blades of gas turbine engines. On the other hand, the issue of extending their service life is still urgent. Shortening the service life of blades is associated, primarily, with a high probability of development of resonance vibrations in them with amplitudes higher than the endurance limit. Another factor leading to shortening of the titanium blade life, is the high sensitivity of the endurance limit to the degree of blade surface perfection. Therefore, damage of blade surface by hard particles (for instance, appearance of scratches) or formation of oxides in the surface layers markedly shorten their operating time.

Increase of the damping capacity of blades, on the one hand, and improvement of wear resistance of their surface, on the other hand, can provide the solution of the above problems. With this purpose the damping capacity of the blade alloy was increased (see, for instance [1]), or coatings of highly ductile materials (Ni, Cu, Ag, Sn, Pb [2-4]) were deposited on the blade surface by electroplating). Such an approach, however, did not promote extension of the titanium blade life. Enhancement of the titanium alloy damping capacity is, as a rule, accompanied by lowering of their endurance limit, and the electroplating coating process did not provide a high adhesion strength of the coating and substrate. Moreover, the electroplating process was accompanied by an essential gas saturation of the substrate, particularly, by hydrogen, this also causing an abrupt lowering of fatigue strength.

Gas saturation of titanium alloys during coating formation on their surface can be avoided and the strength of adhesion between the coating and substrate can be increased, for instance in the case, when the EB PVD method is used for these purposes. As was demonstrated in [5-6] use of this approach allows forming

Movchan, B.A.; Ustinov, A.I. (2005) Highly Damping Hard Coatings for Protection of Titanium Blades. In *Evaluation, Control and Prevention of High Cycle Fatigue in Gas Turbine Engines for Land, Sea and Air Vehicles* (pp. 11-1 – 11-16). Meeting Proceedings RTO-MP-AVT-121, Paper 11. Neuilly-sur-Seine, France: RTO. Available from: <http://www.rto.nato.int/abstracts.asp>.

Highly Damping Hard Coatings for Protection of Titanium Blades

a highly damping coating with a high adhesion strength without reducing from the fatigue strength of the samples without coating.

In order to protect the titanium blade surface from damage, hard coatings are deposited on their surface, for instance, on titanium nitride base. On the other hand, no significant increase of the titanium blade service life is observed in this case, chiefly because of lowering of the endurance limit of the coated blade, which is due to a low endurance limit of hard coatings. Cracks initiating into the coating, penetrate into the substrate, thus lowering its endurance limit, compared to uncoated material.

In view of the above, a logical step would be creation of a coating that would include highly damping and hard erosion-resistant interlayers, separated from the substrate by a layer of highly ductile material.

In the paper Sn-Cr-MgO system is used as an example to demonstrate the possibility of producing by EB PVD technology a graded structure of coatings that is characterized by high damping properties and high hardness.

Coating composition was selected proceeding from the principle that for the coating to have high dissipative properties, its composition should include elements, which could be the basis for forming highly ductile components (ductile layers, ductile particle inclusions in the matrix), and elements ensuring formation of the hard matrix. Tin was used as the highly ductile element and magnesium oxide with chromium additives as the base for hard matrix formation. It is obvious that in practical terms when the ductile interlayers are located near the substrate, and the hard ones - in the coating upper part is preferable.

The coating graded structure was formed using the method of electron beam evaporation of tablets, consisting of a mixture of components taken in the proportion corresponding to the coating composition.

2.0 PROCEDURE OF PRODUCING AND STUDYING THE COATINGS

2.1 Electron Beam Technology of Graded Coating Deposition

Graded coatings based on Sn-Cr-MgO system were produced using the method of electron beam evaporation under vacuum of samples (tablets) [8], consisting of a mixture of powders of Sn (99.99% purity), Cr (99.9%) and MgO (99%).

Tablets prepared in such a way (50 mm diameter and 70 ... 100 g weight) were placed into a vacuum chamber on a water-cooled substrate and were evaporated by an electron beam gun. Fig. 1 gives the schematic of electron beam deposition of coatings on a substrate, which was placed directly above the tablet at a certain distance (300 mm) from it. The substrate was attached to a holder, which was heated up to a specified temperature by another electron beam gun (not higher than 400°C). Temperature monitoring was performed by a thermocouple, the junction of which was in contact with the substrate.

Before fastening the substrate on a holder, its surface was treated by mechanical polishing, and then ultrasonic cleaning in acetone. After pumping down the chamber volume, the substrate surface was treated by ion cleaning by argon atoms, using an ion source located under the holder (Fig. 1). At the final stage of cleaning the substrate was heated up to the specified temperature and the process of electron beam evaporation of the tablet was started.

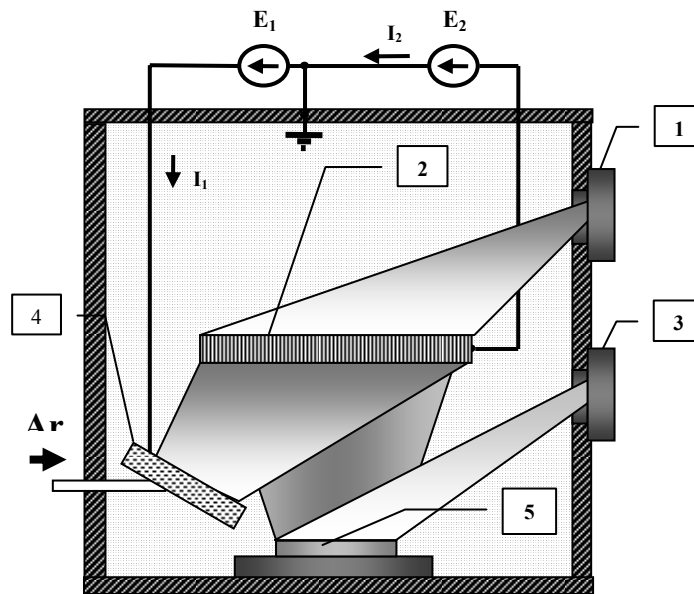

Figure 1: Schematic of a single-step process of graded coating deposition. 1 – electron beam gun for heating; 2 – holder for substrate; 3 – electron beam gun for evaporation; 4 – ion source; 5 – composite tablet.

Coating thickness was varied in the range from 20 up to 100 μm by changing the tablet weight.

2.2 Procedure of Studying the Structure, Composition of Coatings and Microhardness

The thus produced coatings were studied by XRD, SEM and TEM methods.

X-ray examination was conducted by Bragg-Brentano method, analyzing the scattered intensity of X-ray radiation of a copper anode from a flat surface of a coated sample.

Transverse sections of a coated sample were prepared by mechanical polishing to study the coating structure. Scanning electron microscope CamScan 4 used by us for microstructural studies of coatings was fitted with ENERGY 200 system, allowing local chemical analysis of element distribution across the coating thickness to be performed. The same samples were further used also for durometric coating studies. Microhardness measurements of the coatings were conducted using on optical Polyvar Met microscope at the loads of 0.196N on the Vickers indenter.

Transmission electron microscopy was used to study the fine structure of the coatings in some cases. TEM samples were prepared on foils separated from the substrate. To produce such foils, CaF was first deposited on the substrate surface. In this case, the coating separated easily from the substrate during cooling. 3 mm diameter washers were cut out of the thus produced foils, in which first a recess was made by machining and then a thinning by ion etching.

2.3 Procedure of Studying the Dissipative Properties of Coatings

Evaluation of the effectiveness of energy dissipation at the expense of the coating was conducted by comparing the logarithmic decrements of free damping vibrations of flat samples supported in cantilever without a coating and with a coating at their bending deformation. Used for these purposes was a mechano-dynamic analyzer [5], the schematic of which is given in Fig. 2.

Highly Damping Hard Coatings for Protection of Titanium Blades

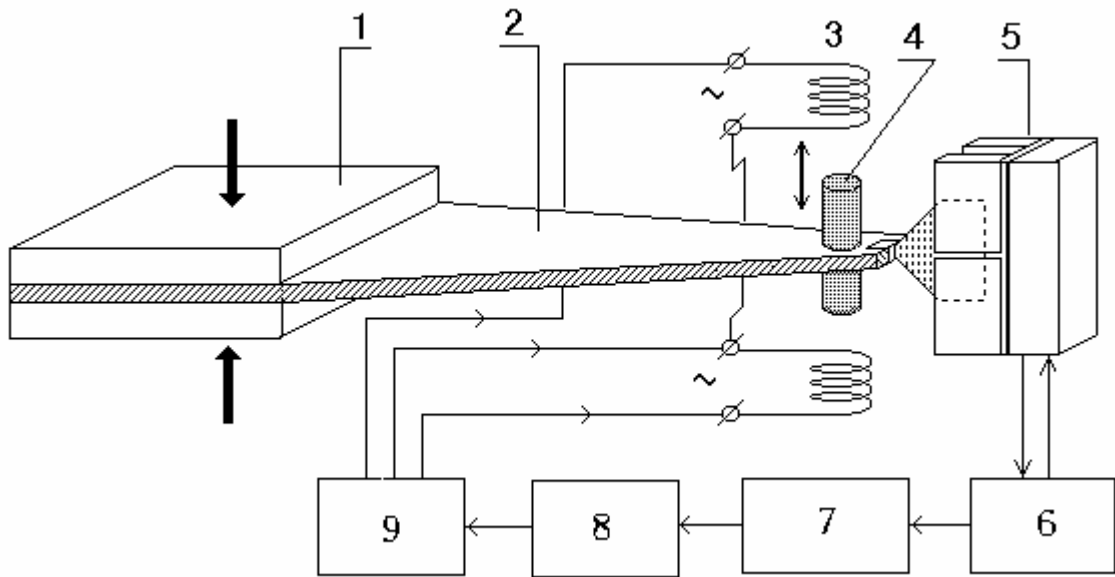

Figure 2: Schematic of a mechano-dynamic analyzer: 1 – holding tool; 2 - sample; 3 – magnet coils; 4 -ferromagnetic buttons; 5 - capacitive sensor; 6 – amplifier; 7- PC; 8 – controlled generator; 9 – power amplifier.

Under cantilever bending of flat rectangular-shaped samples the magnitude of deformation on the surface differs for the sections located at different distances from the location of its constraint. To reduce the scatter of deformation applied to the coating in different regions of the substrate at its bending, the substrates were trapezoidally shaped. Additionally the value of coating deformation scatter could also be reduced by coating deposition on just part of the substrate. Using these approaches allow the deformation scatter to be reduced to the value of 10%.

To record the oscillogram of free damping vibrations, the sample was swung up to maximum amplitude at the resonance frequency, and then the current in electromagnet coils exciting the sample vibrations, was switched off. Analyzing the oscillogram of damping vibrations of a sample in its different sections, the dependence of damping decrement of vibrations was determined proceeding from the relationship of

$$\delta(\bar{\varepsilon}_i) = \frac{1}{n} Ln \frac{A_i}{A_{i+n}},$$

where A_i and A_{i+n} is the magnitude of vibrations of the free end of the sample at the i th and $i+n$ -th vibrations, $\bar{\varepsilon}_i$ is the mean value of the coating deformation amplitude in the range between the i th and $i+n$ -th vibrations.

As the characteristics of energy dissipation in as-deposited coatings at the initial stages of cycling loading were characterized by high values, which changed significantly (decreased) under cyclic loading, in order to determine stable values of damping capacity of the samples, they were subjected to cyclic loads at maximum amplitudes (Up to $3 \cdot 10^{-3}$) at $1 \dots 3 \cdot 10^3$ vibration cycles. After such cyclic loading (“training”) the samples demonstrated stable values of the damping capacity.

To study the temperature dependence of energy dissipation by coatings, the coated part of the sample was placed into a furnace, and heated up to the specified temperature, which was maintained during the period of recording the oscillograms of free damping vibrations.

Preliminary studies of the dissipative properties of uncoated samples showed, that their heating up to 400°C does not lead to an essential change in the amplitude dependence of the sample, and, therefore, the

observed changes of the dissipative properties of coated samples at heating can be attributed to the coating proper.

3.0 STRUCTURE AND PHASE COMPOSITION OF COATINGS

Fig. 3 gives an example of coating microstructure and chemical element distribution along its cross-section, which formed during evaporation of tablets of the following composition: 10wt.%Sn-15%Cr-MgO. The intensity of scattered electrons shows that the graded coating can be conditionally divided into two zones, namely a lighter zone adjacent to the substrate and the zone (main) with blackening enhanced in the direction away from the substrate. Element distribution shows that the light zone is enriched with tin and chromium, whereas the extended zone consists mainly of magnesium oxide. Such a graded structure is due to the fact that under the impact of the electron beam tin and chromium are the first to start evaporating from the tablet, and then the intensity of tin evaporation becomes smaller. As the tablet is heated, the intensity of magnesium oxide evaporation increases, becoming dominant at formation of the coating upper layers. The intensity of chromium evaporation is also stabilized.

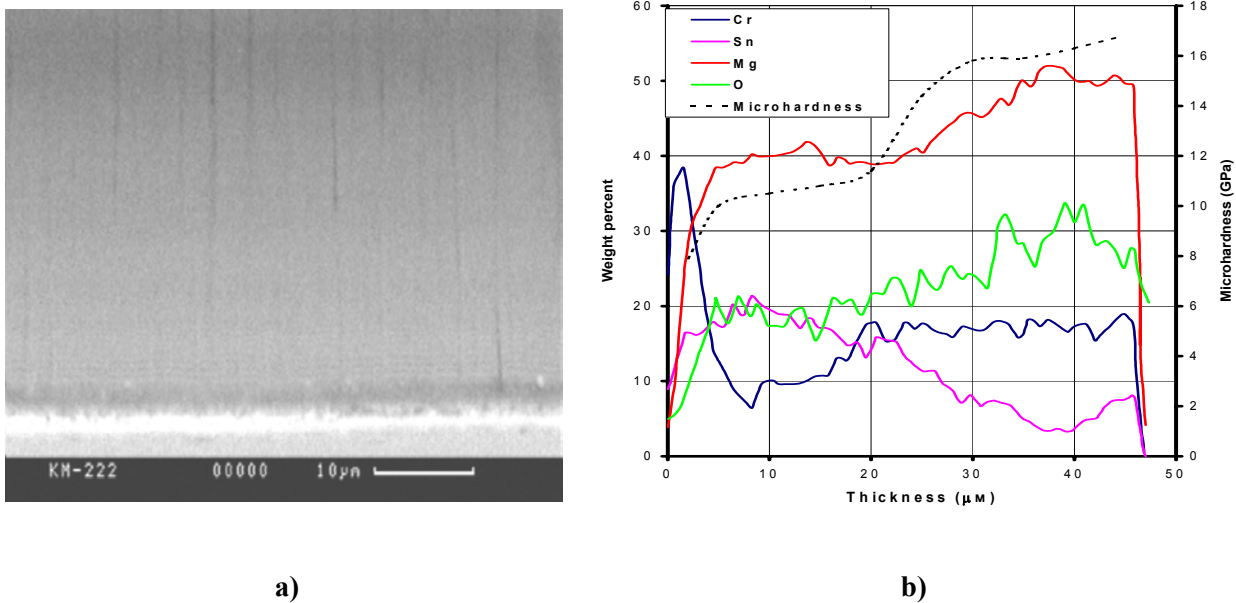

Figure 3: Microstructure (a) and distribution of chemical elements and variation of microhardness value along the sample cross-section in the coating cross-section (b).

Investigation of coating microhardness along its cross-section showed (Fig. 3b) that it rises monotonically in the direction away from the substrate, reaching the maximum value (about 17 GPa) in the coating upper layers.

Diffraction patterns obtained from the coating upper layers show diffraction peaks, which correspond to the presence of chromium and magnesium oxide in the coating structure. It should be noted that the diffraction peaks of magnesium oxide are significantly wider. This may be indicative of small dimensions of the crystallites (coherent scattering fields) based on magnesium oxides. Evaluation showed that, if the width of the diffraction peaks is due to just the dimensional factor, then, in keeping with Sherrer formula, the crystallite dimension should be equal to a value of the order of 5 to 10 nm.

Highly Damping Hard Coatings for Protection of Titanium Blades

Transmission electron microscopy studies of the coating structure confirmed these evaluations. As is seen from the dark field image of the microstructure (Fig. 4), taken in the magnesium oxide reflection, and their statistical analysis (Fig.5), the mean dimension of crystallites is below 10 nm.

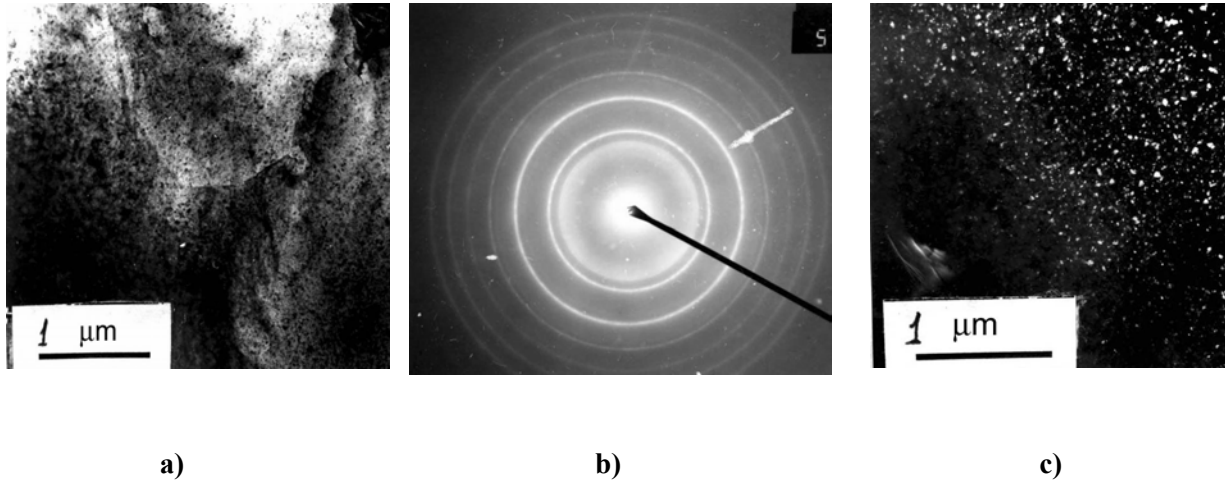

Figure 4: Electron microscopy image of the coating structure : a) light field; b) microdiffraction; c) dark field taken in the reflection from magnesium oxide.

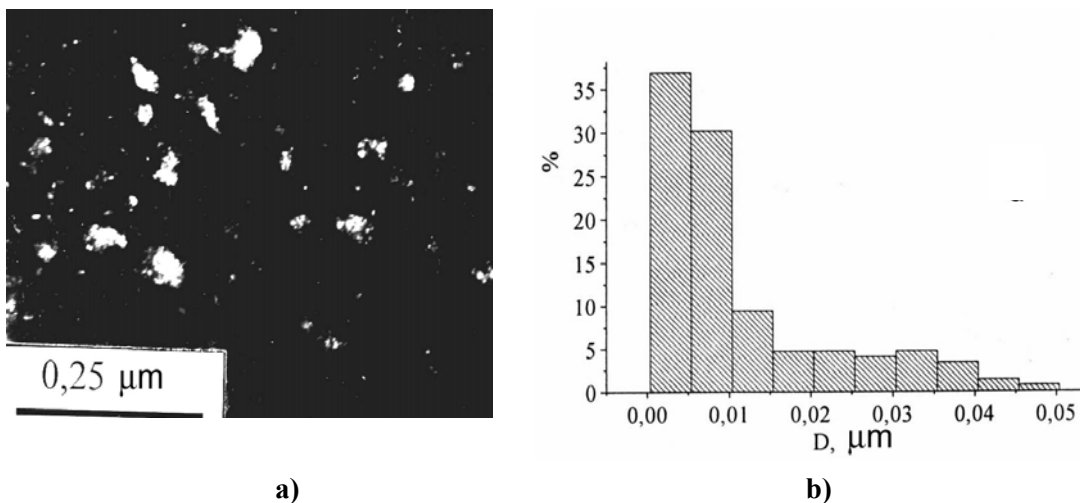

Figure 5: Dark field electron microscopy image of the coating structure taken in the reflection from magnesium oxide (a) and size distribution of magnesium oxide grains (b).

However, except for regions of nano-sized structure based on magnesium oxide, the coating structure also has regions enriched with chromium, where the characteristic dimension is about 1 μm. Microdiffraction patterns taken from large coating regions have other reflections, in addition to magnesium oxide reflection. Their analysis showed that the coating has a multiphase structure, which in addition to MgO also has in its composition such compounds as Cr₂O₃, CrO₂, SnO₂, MgCr₂O₄, Mg₂SnO₄ and Mg₂Sn as the most probable ones.

Thus, during deposition of the vapour flow formed at tablet evaporation onto substrates, which are at temperatures not higher than 400°C, metal-ceramic coatings graded across their thickness form, which consist of a tin-enriched zone (layers adjacent to the substrate) and zone based on magnesium oxide (upper layers of the coating). In this case, an inhomogeneous composition is found in the coating upper layers, namely coarse (up to 1 μm) inclusions enriched in chromium, are present in addition to regions enriched in magnesium oxide. Dimensions of structural elements of the coating upper layers are of a nano-sized scale and are characterized by a heterophase composition.

4.0 RESULTS OF FATIGUE TESTING OF COATED SAMPLES

As the mechanical properties of the substrate and coating differ significantly, it might have been anticipated that deposition of metal-ceramic coatings will lead to decrease of the endurance limit of such samples, compared to uncoated samples. Fig. 6 gives the results of high-cycle testing of uncoated samples and samples with graded coatings, consisting of layers based on ductile elements (Sn), adjacent to the substrate, and hard upper layers based on oxides. It should be noted that uncoated samples were subjected to the same cycle of heat treatment, which was applied to samples during coating deposition.

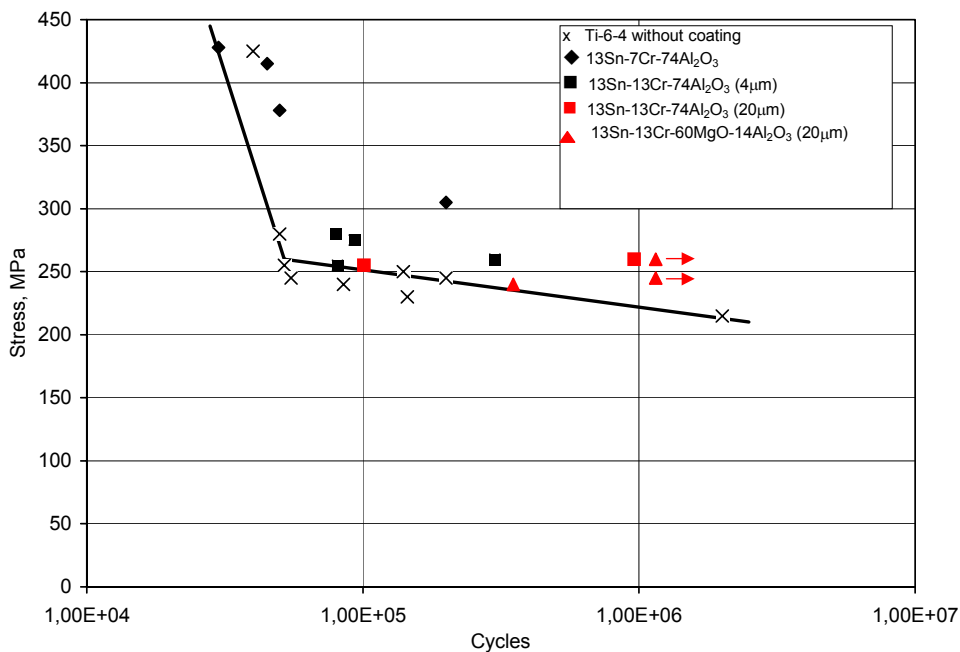

Figure 6: Dependence of the number of flat sample vibrations up to their fracture on the magnitude of deformation amplitude.

Comparison of the results of testing uncoated samples and samples with graded coatings, based on oxides showed that the number of cycles to coated sample fracture does not differ from that for the uncoated samples, and is even higher in a number of cases. This suggests that deposition of graded coatings of this type does not lead to decrease of the sample endurance limit.

The obtained result is unexpected, considering that the ceramic materials usually have a low endurance limit and are characterized by the brittle fracture mode. For this reason, such coatings lead to an abrupt lowering of the sample endurance limit.

Highly Damping Hard Coatings for Protection of Titanium Blades

Microstructural studies of samples after cyclic loading were conducted to clarify the reasons for preservation of the endurance limit of coated samples, compared to the same samples without a coating.

Fig. 7 shows a microstructure of the cross-section of a sample subjected to fatigue testing (on 10^6 cycle base) in the region of the highest stress level, which arise at alternating loading. Investigations showed that cracking develops in the coating. It should be noted that cracks located normal to the substrate, were arrested in the tin-based ductile layer and did not reach the substrate surface.

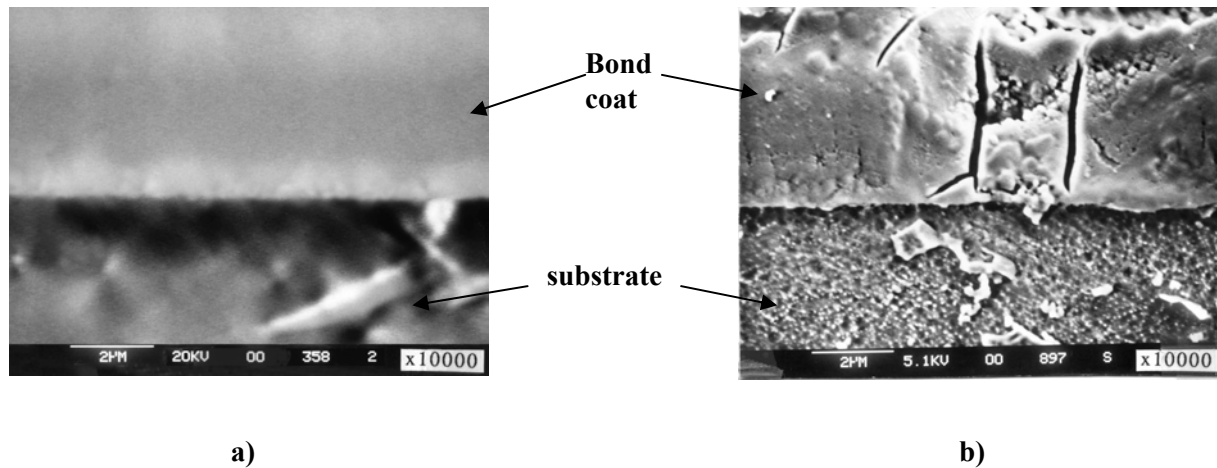

Figure 7: Microstructure of the cross-section of a sample with coating before (a) and after (b) cyclic loading.

Thus, it may be assumed that absence of the influence of graded coatings, consisting of ductile bond coats adjacent to the substrate and hard upper layers, on the fatigue properties of samples may be related to arresting of fatigue crack propagation from the coating hard layers into the substrate materials. In the case of formation of hard layers based on magnesium oxide, it should be also taken into account, that as the coefficient of linear thermal expansion of the magnesium oxide is greater than that of the titanium alloy, the coating will develop compressive stresses on the base metal surface during cooling, this also promoting prevention of crack opening in the subsurface layers of the titanium substrate.

5.0 DAMPING CAPACITY OF THE COATINGS

Typical form of amplitude dependence of the damping decrement of vibrations in sample with graded coatings is given in Fig. 8. It is seen that for coated samples, the level of vibration energy dissipation is essentially higher, compared to the same uncoated samples.

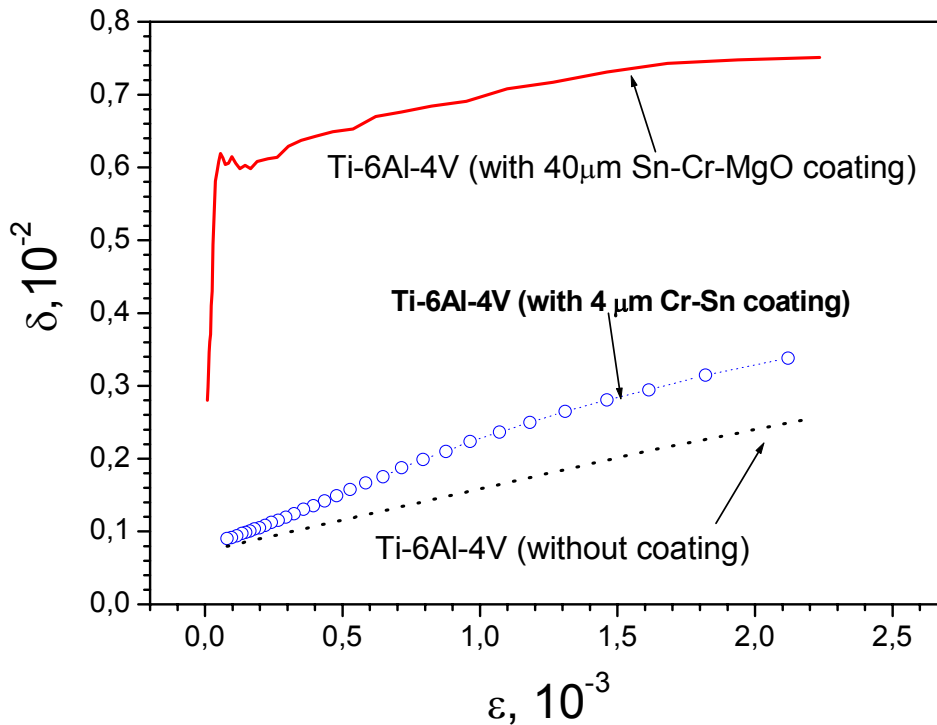

Figure 8: Amplitude dependencies of the damping decrement of samples with Sn-Cr-MgO and Sn-Cr based coatings.

Considering that the coating structure can be conditionally presented as consisting of two zones with a smooth transition from the first Cr-Sn-based ductile zone to the second hard zone, based on magnesium oxide, it may be assumed that the higher damping level of such samples is due to presence of the first zone in the coating structure. Indeed, as shown by studies of samples with coatings based on Cr with Sn additives, such coatings are characterized by a higher level of vibration energy dissipation. However, as seen from Fig. 8, the damping level, higher compared to the uncoated sample, in the case of applying coatings based on Sn-Cr system, is several times lower than the level observed experimentally. It should be also taken into account that the thickness of Cr-Sn-based coatings is two times higher than the thickness of the first zone of the graded Sn-Cr-MgO coating. In addition, amplitude dependence of the damping decrement of samples with Cr-Sn-based coatings differs qualitatively from those observed in the case of metal-ceramic coatings.

It is known that if the ductile material of the coating is divided by hard material interlayers, the dissipative properties of such a composite coating are increased. This is associated with greater shear component in the ductile layers at tensile deformations of the coating [2,9-10]. However, with increase of the hard layer thickness, the dissipative properties of such a composite will decrease.

Another regularity is observed in the case of increase of the metal-ceramic coating thickness under the conditions, when the ductile zone thickness is practically unchanged. With increase of the coating thickness the dissipative properties of the coating rise practically linearly. This led us to the conclusion that the high level of dissipation of vibrations energy in samples with graded coatings based on Sn-Cr-MgO system is chiefly due to the metal-ceramic layers of the coating.

Highly Damping Hard Coatings for Protection of Titanium Blades

One of the possible sources of vibration energy dissipation could be the tin particles, which may form in the ceramic matrix during simultaneous deposition of tin and magnesium oxide. However, it is notable that the amplitude dependencies of the damping decrement have a linear form in the entire range of deformation amplitudes for uncoated samples, and at deformation amplitudes above a certain value (10^{-4}) for coated samples. The slope of these dependencies is practically the same for both the samples. If we assume that dissipation of vibration energy in a coated sample consists of the contribution of the substrate and the coating into its scattering, it may be concluded that the coating damping capacity does not depend on amplitude.

Absence of amplitude dependence of the damping decrement is not characteristic of damping due to the dislocation mechanisms [2-3,5] of energy dissipation.

Study of the mechanical characteristics of materials in the nano-structured state [11] reveals that the strength properties of materials with such a structure start deteriorating at grain refinement to a certain critical size. This phenomenon ("reverse" Hall-Patch) is associated with the fact that at refinement of the grain size the mechanism of plastic deformation changes from a predominantly dislocation mechanism to mechanisms related to processes proceeding at the grain boundary (grain-boundary slipping, grain motion, dislocation generation, etc.). An important condition for implementation of these processes under the impact of stresses induced by the external forces is the diffusion mobility of atoms on the grain boundaries. It means that the intensity of energy dissipation in materials due to grain-boundary processes should not have a strong amplitude dependence. This suggests that dissipation of vibration energy in the studied coatings can be due to the phenomena of grain-boundary relaxation. In this case it may be anticipated that at temperature increase the coating damping capacity will rise, independent of the coating deformation amplitude.

Fig. 9 shows the amplitude dependencies of the damping decrement of a sample with Sn-Cr-MgO based coating at its heating. It is seen that the coating dissipative capability rises at heating. At cooling it is restored to the initial values. Note that the form of the amplitude dependence in this case remains practically unchanged, this being an indirect confirmation of the proposed model of damping in the studied coatings.

As the value of vibration energy dissipation due to grain-boundary relaxation depends on the extent and condition of the boundaries, it could be anticipated that at substrate temperature lowering the coating dissipative properties would also change because of the change of the coating material structural element dimensions. Study of samples with coatings deposited at temperatures from 250 to 450°C showed that, indeed, lowering of the temperature of coating deposition leads to a change in their dissipative properties. Not only the damping level is changed, but also the form of its amplitude dependence. As an example, Fig.10 gives the amplitude dependence of the damping decrement for a sample with a coating deposited at substrate temperature of 300°C. It is seen that unlike the amplitude dependencies of the damping decrement in samples with coatings deposited at the temperature of 400°C, the presented dependencies are characterized by a damping maximum in the region of small deformation amplitudes ($5 \cdot 10^{-4}$).

Highly Damping Hard Coatings for Protection of Titanium Blades

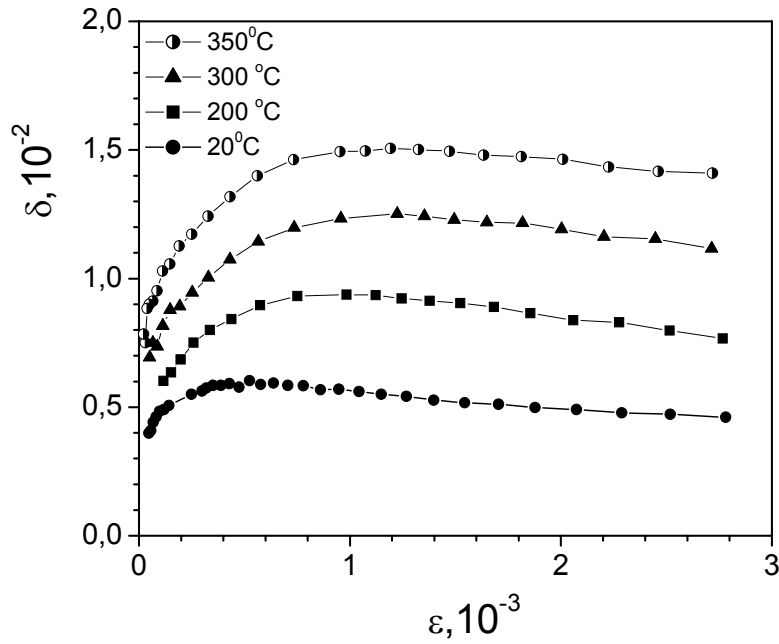

Figure 9: Change of amplitude dependence of the logarithmic decrement of vibration due to Sn-Cr-MgO coating at heating. Curves were obtained as a result of subtraction from the $\delta(\epsilon)$ values of sample with coating the $\delta(\epsilon)$ values of sample without coating.

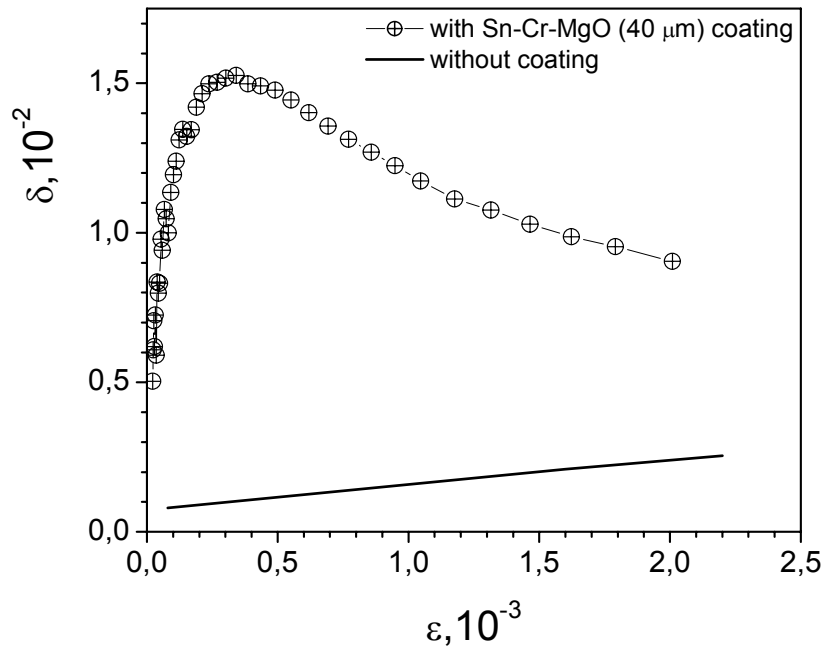

Figure 10: Amplitude dependence of the damping decrement for a sample with Sn-Cr-MgO coating deposited at substrate temperature of 300°C.

Highly Damping Hard Coatings for Protection of Titanium Blades

Such samples also demonstrate an unusual change of their resonance frequency during “training”. If in the case of coatings deposited at temperatures close to 400°C, the resonance frequency remains practically unchanged during the specimen “training”, in the case of samples with coatings deposited at the temperature of 300°C, the resonance frequency changes jumplike to a certain value, and then is stabilized at further alternating loading. Such a change of the resonance frequency at cyclic loading of the samples usually precedes their fatigue fracture. This phenomenon is associated with formation of fatigue cracks in the material. A maximum also appears on amplitude dependencies of the damping decrement of such samples (Fig. 11) in the region of small deformation amplitudes. The magnitude of this maximum rises with the increase of the number of vibration cycles. One of the most probable mechanisms of energy dissipation in this case are regarded to be the processes associated with a change in the fatigue crack configuration, namely crack opening and closure [12].

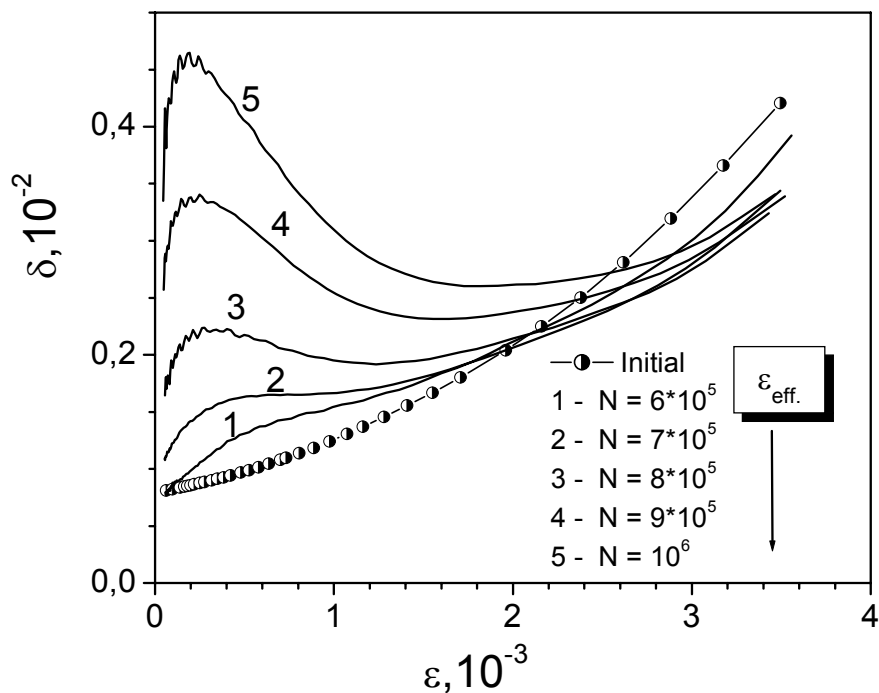

Figure 11: Amplitude dependence of damping decrement of flat samples after cyclic loading at amplitude deformation ε_{eff} .

By analogy with energy dissipation in materials with fatigue cracks, it may be assumed that energy dissipation due to a change in the configuration of material discontinuities predominates in coatings formed at a lower temperature.

One of the sources for discontinuity formation may be vacancy-type defects, the concentration of which rises essentially at lowering of the substrate temperature. At the initial stages of cyclic loading, the mobility of vacancies rises, this promoting formation of vacancy clusters and nanopores. As the grain sizes in such structures are below 10 nm, the grain boundaries are the most probable vacancy drains. This circumstance will promote formation of flat vacancy clusters, which may change their configuration under the impact of external stresses, which is what will cause dissipation of sample vibration energy.

Such vacancy clusters differ from the cracks in that at high-cycle loading the dissipative properties of a coated sample remain stable up to 10^6 cycles, and the start of fatigue fracture of the substrate material. The high degree of stability of the dissipative properties at multiple alternating loading indicates that energy

Highly Damping Hard Coatings for Protection of Titanium Blades

dissipation in the vacancy clusters formed as a result of microplastic deformation of the coating in the nano-structured state, is controlled at alternating loading by reversible phenomena of vacancy cluster configuration change without any change of their dimensions and concentration.

In the case of deposition of coatings at intermediate substrate temperatures, the amplitude dependencies are characterized both by the presence of a maximum in the region of small deformation amplitudes, and the availability of a region of amplitude-independent damping (at higher amplitudes). At alternating loading of such samples in the region of increased deformation amplitudes a certain lowering of the level of vibration energy dissipation is observed at higher deformation amplitudes, while at small deformation amplitudes the dissipative ability of the coating remains practically unchanged (Fig. 12).

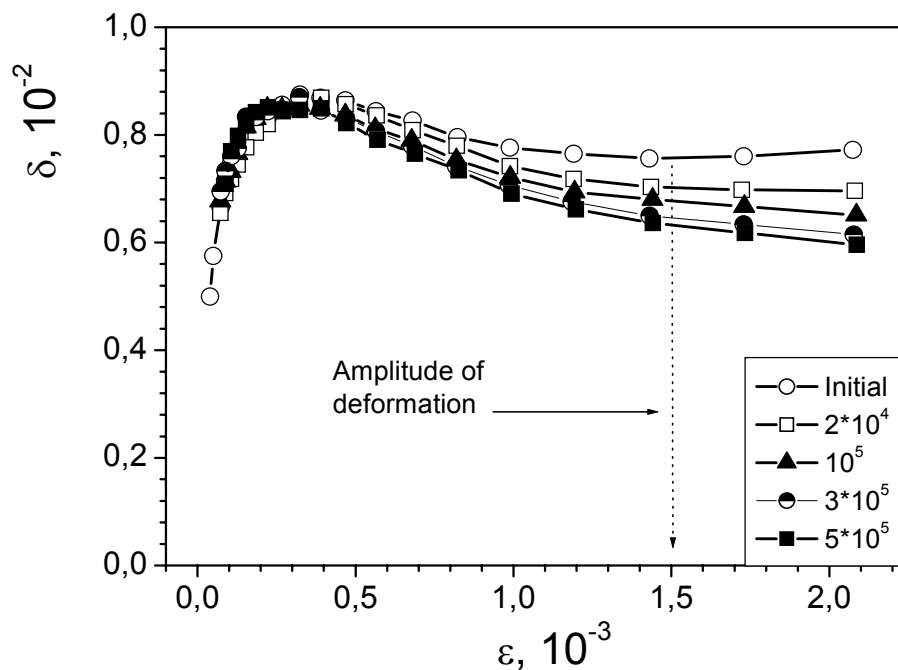

Figure 12: Change of amplitude dependence of the damping decrement under the impact of cyclic loading for samples with Sn-Cr-MgO coatings, deposited at substrate temperature of 350°C.

From the above model of vibration energy dissipation in metal-ceramic coatings with nano-sized structural elements, it follows that energy dissipation due to vacancy clusters is more resistant to cyclic loading than scatter due to grain-boundary relaxation. The latter, in all probability, is accompanied by irreversible phenomena proceeding on grain boundaries, whereas the concentration and dimensions of nano-pores remain practically unchanged at cyclic loading of samples (or the rate of these phenomena proceeding is very low). To determine the stability of coating properties in the temperature modes, in which a blade can operate, the coated and uncoated samples were subjected to long-term (up to 300 h) annealing at a higher temperature (500°C) with subsequent determination of their mechanical properties. It turned out that such heating does not have any significant influence on microhardness or damping capacity of the coating.

Similar studies were conducted also for low-temperature treatment. Coated samples were treated by multiple cooling to the liquid nitrogen temperature with subsequent heating to room temperature. Such a low-temperature thermal cycling does not lead to any change of sample properties, either.

Conducted studies lead to the conclusion that the studied coatings can perform in a wide temperature range (from 196 to 500°C) without any change of their mechanical properties.

Highly Damping Hard Coatings for Protection of Titanium Blades

6.0 CONCLUSION

Sn-Cr-MgO system was used as an example to demonstrate the possibility of developing graded coatings with grain size on a nano-sized scale, having a high damping capacity, which rises at heating right up to 400°C, high hardness ($H\mu = 16 \dots 17$ GPa) and high strength of adhesion to the titanium substrate. High damping capacity of the nano-structured states of the metal-ceramic composite is associated with the mechanisms of grain boundary relaxation and evolution of the vacancy cluster configuration (opening and closing, for instance, of nano-pores) under the impact of alternating loading. Absence of degradation of fatigue strength of titanium samples at coating deposition on them is due to the coating graded structure, which implies formation of ductile layers near the substrate and their smooth transition to hard layers of the coating.

It is shown that the high degree of reproducibility of the graded structure, composition and properties of coatings can be ensured, for instance, by a single-step process of electron beam evaporation in vacuum of a composite tablet, consisting of pure elements and compounds, and deposition of the vapour phase on the substrate, which is at a temperature not higher than 350 ... 400°C.

An unusual combination of properties of graded coatings based on Sn-Cr-MgO (high damping ability, high hardness, adhesion strength of the bond with the titanium substrate, and absence of an adverse influence of the coating on the sample endurance limit), stability of their properties at thermomechanical loading and possibility of deposition of such coatings on titanium alloys at lower temperatures (below 400°C) allows considering them as a basis for development of coatings capable of essentially extending the service life of gas-turbine compressor engine blades.

7.0 ACKNOWLEDGEMENT

The financial support of this study by EOARD through STCU under project number P125 is gratefully acknowledged by authors.

8.0 REFERENCES

- [1] Yakovlev A.P., Beregovenko A.Yu., Lukyanov V.G. Markovskiy P.E. (1999) *Thermomechanical Treatment Effect on Damping*. Problem Strength, N1, p. 95.
- [2] Yakovlev A.P. (1985) *Dissipation properties of nongomoginies materials and systems*. Kyiv, Naukova Dumka, 248 p.
- [3] Favstov Yu.K., Shulga Yu.N., Rakhshadt A.G. (1980) *Material Science of Highly Damping Alloys*, Moscow, Metallurgizdat, 271 p.
- [4] Ilinskii A.I.(1989) *Structure and Properties of Layered and Age-Hardened Films*. Moscow, Metallurgizdat, 141 p.
- [5] Ustinov A.I., Movchan B.A., Skorodzievskiy V.S. (2001) *Study of Damping Capacity of Ti-6-4 Alloy Flat Samples with Tin and Yttrium coatings*. Strength Problems, N4, p. 55.
- [6] Ustinov A.I., Movchan B.A., Lemkey F., Skorodzievskiy V.S. (2001) *Damping Capacity of Co-Ni and Co-Fe Coatings Produced by EBPVD Method*. Vibration in Technique and Technology, N4, p.123.
- [7] Xinhua X., Jinghuan Z., Zhongda Y., and Zhonghong L. (1997) *Fabrication and microstructure of ZrO₂/NiCrCoAlY graded coating by plasma spraying*. Surface and Coating Technology, **88**, p.66.

Highly Damping Hard Coatings for Protection of Titanium Blades

- [8] Movchan B.A. (2002) *Functionally graded EBPVD Coatings*. Surface and Coating Technology., **149**, p.252.
- [9] Plunkett R., Lee C.T. (1970) *Length Optimization for constrained viscoelastic layer damping*. J. Acoust. Soc. **48**, N1, p.150.
- [10] Dubenets V.G. (1970) *Vibrations of Trilaminar plates considaration of dissipation energy in material*. Strength problems, **9**, p.25.
- [11] Andrievskiy R.A., Glezer A.M. (1999) *Size effect in Nanocrystaline materials*. Fizika Metallov i Metallovedenie, 88, N1, p.55.
- [12] Suresh S., Ritchie R.O. (1982) A geometrical model for fatigue crack closure induced by fracture surface roughness. Met. Trans. A. **13**, N9, p.1627.

SYMPOSIA DISCUSSION – PAPER NO: 11

Author's name: A. Ustinov

Discussor's name: G. Harrison

Question: The author showed the effect of increased damping capacity with increase in temperature up to 300C, but engine fans can run at -50C. For completeness is it necessary to test at sub zero temperatures?

Answer: This is being considered.